



INSTALLATION & OPERATION MANUAL FOR INVERTER OF 10~20KTL

THE POWER OF ASTROENERGY



ASTROENERGY

A **CHNT** COMPANY

INSTALLATION & OPERATION MANUAL FOR INVERTER OF 10~20KTL

1. Introduction

- 1.1 Validity
- 1.2 Target Group
- 1.3 Product Overview
- 1.4 Safety

2. Unpacking

- 2.1 Unpacking and Inspection
- 2.2 Information of Label

3. Mounting

- 3.1 Safety instruction
- 3.2 Selecting the Installation Location
- 3.3 Installation guidance

4. Electrical Connections

- 4.1 Types of Grid Structure and Connection Compatibility
- 4.2 Wiring AC Output
- 4.3 Wiring DC Input
- 4.4 RS485 cable connection

5. Heat Dissipation Maintenance

- 5.1 Cleaning Fans and Grills
- 5.2 Exchanging Fan

6. Commission the Inverter

7. Operation Modes

- 7.1 Normal mode
- 7.2 Fault mode
- 7.3 Shutdown mode

8. LCD Display

- 8.1 Country Setting
- 8.2 General LCD display
- 8.3 Operate by knock
- 8.4 Data checking and parameters setting
- 8.5 Inverter faulty messages

9. Communitions

- 9.1 Astronergy Net
- 9.2 Astronergy Vision
- 9.3 Astronergy Pano
- 9.4 Astronergy WebBox

10. Trouble Shooting

- 10.1 General question
- 10.2 Error Messages displayed on LCD

11. Specifications

12. Astronergy Factory Warranty

13. Warranty Conditions

14. Contact

1. Introduction

1.1 Validity

This installation guide contains installation, commissioning, communication, trouble shooting. information of Astronergy CHPI KTL series inverters:

- CHPI 10KTL
- CHPI 12KTL
- CHPI 18KTL
- CHPI 20KTL

With this installation guide, users are able to install and operate the inverters easily. This manual does not cover any details concerning equipment connected to the Astronergy CHPI KTL. Store this manual where accessible at all times.

1.2 Target Group

This manual is for qualified persons such as PV system installers or electricians.

Notes: For possible changes in this manual, Chint Solar(Zhejiang) Co., Ltd. accepts no responsibilities to inform the users.

1.3 Product Overview

Astronergy CHPI KTL series inverters are grid-tied inverters which convert DC current generated by PV modules into AC current and feed it into the public grid in three-phase. Astronergy CHPI KTL series inverters are multi-string inverters with multi-MPP trackers, which mean they are able to connect to different PV module arrays.

Inverters Overview:

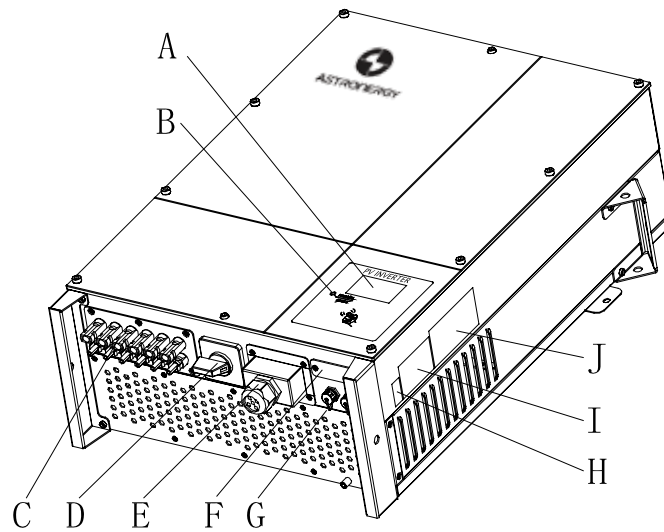



Fig 1.1

Position	Description
A	LCD
B	LED
C	PV input terminals
D	DC Switch
E	AC output
F	RS232 lid
G	RS485
H	Series Number
I	Warning Label
J	Type label

Symbol on the inverter

Symbol	Description	Explanation	
	Tap symbol	Indicates display operation (see Section 6).	
	Inverter status symbol	Green/constant	Operation
		Red/constant	1. Fault-- contact installer 2. Standby module
		Red/flashing	1. Fans Fault-- contact installer 2. Software update

Grid-tied PV system Overview:

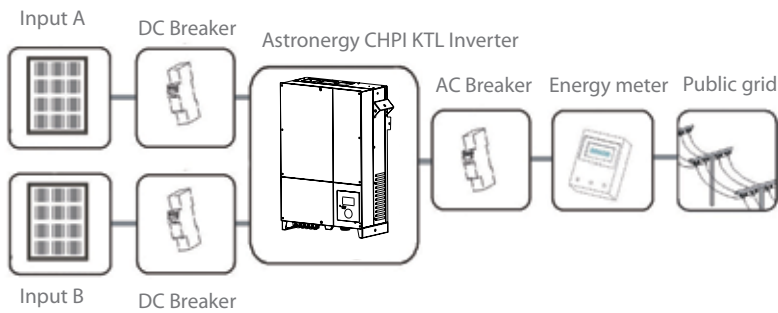

Fig 1.2

As drawings shown above, a complete Grid-tied PV system consists of PV modules, PV inverters, public grid and other components. Moreover, PV inverters always act as key components.

The Astronergy CHPI KTL series inverters may only be operated with PV generators (modules and cabling) with protective insulation. Do not connect any source of energy other than PV modules to the Astronergy CHPI KTL series.

When design a PV system contains Astronergy CHPI KTL series inverters or any other Astronergy inverters, the system designing software AstronergyDesign (download from site: www.astronergy.com) will provide adequate supports.

Notes: If PV modules of the PV system require POSITIVE or NEGATIVE GROUND, or the capacitance relative to ground of the modules is large, please contact Astronergy for technical support before installation.

1.4 Safety

Astronergy CHPI KTL is designed to use worldwide, hence the inverters meet different safety standards of variety countries and regions.

VDE-AR-N 4105; BDEW; CEI 0-21; IEC 62109 1/2; VDE0126-1-1; RD1663; G59; CE

DANGER!

Danger to life due to high voltages in the inverter!

All work on the inverter may be carried out by qualified personnel only.

The appliance is not to be used by children or persons with reduced physical, sensory or mental capabilities, or lack of experience and knowledge, unless they have been given supervision or instruction.

Children should be supervised to ensure that they do not play with the appliance.

CAUTION!

Danger of burn injuries due to hot enclosure parts!

During operation, the upper lid of the enclosure and the enclosure body may become hot.

Only touch the lower enclosure lid during operation.

CAUTION!

Possible damage to health as a result of the effects of radiation!

Do not stay closer than 20 cm to the inverter for any length of time.

Grounding the PV generator

Comply with the local requirements for grounding the PV modules and the PV generator.

Astronergy recommends connecting the generator frame and other electrically conductive surfaces in a manner which ensures continuous conduction and ground these in order to have optimal protection of the system and personnel.

CAUTION!

Possible damage the PV modules as a result of Identification of String Failure!

The Astronergy CHPI KTL Inverter is equipped with a system which recognizes total failure of individual strings or part-strings.

2. Unpacking

2.1 Unpacking and Inspection

Before opening the packing box of Astronergy CHPI KTL, please note that whether there are any visible external damages.

Once open the packing box, please check the delivery for completeness and for any visible external damages of the inverter. If there are anything damaged or missing, please contact your dealer. Complete delivery should contain as follows.

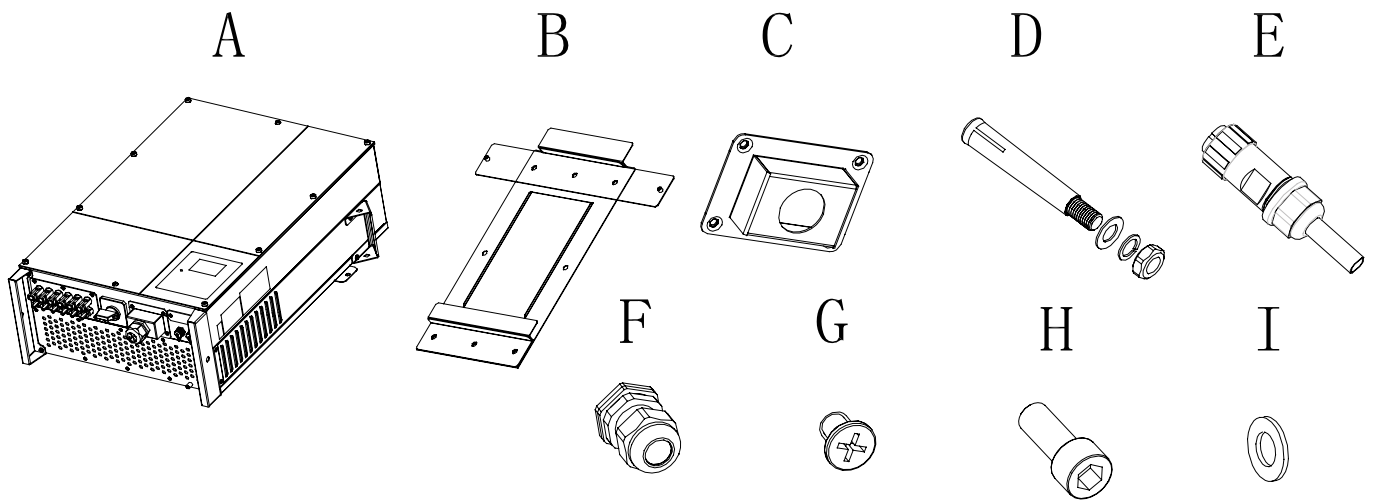

Fig 2.1

Item	Number	Description
A	1	CHPI KTL inverter
B	1	Mounting frame
C	1	Waterproof cover
D	6/8	Explosion screw
E	2	RS485 connector
F	1	Cable gland for AC connection
G	4	M4 cross recessed countersunk head screws
H	3	M6 socket head cap screws
I	2	Flat mat
---	1	Warranty(not show in the picture)
---	1	User manual (not show in the picture)



Hint: Number of D is 6 for CHPI 10/12 KTL, and 8 for CHPI 18/20 KTL.

Notes: Though the packaging box of Astronergy CHPI KTL is durable, please treat the packing box gently and avoid dispose the packing box.

2.2 Information of Label

The label contains information as below:

- The inverter type/model (Model Name);
- The certificates and approvals (Certificate Number and Logos at the bottom of the label);
- Specifications of the inverter (From U_{DC}max to Operation Ambient Temperature).

		PV Grid-connected Inverter A CHNT COMPANY
Model Name	CHPI 10KTL	
U_{DC} max	1000V	
I_{DC} max	2×15A	
U_{DC} range	300V~1000V	
V_{AC} norm	3/N/PE 230V/400V	
f_{AC} norm	50Hz	
P_{AC} norm	10kW	
I_{AC} norm	14.4A	
I_{AC} max	16A	
PF	0.9leading~0.9laging	
Protection Degree	IP65	
Operation Ambient Temperature	-25°C~60°C	
 VDE-AR-N4105		

3. Installation

3.1 Safety instruction



Danger to life due to fire or explosion

- Despite careful construction, electrical devices can cause fires.
- Do not install the inverter on easily flammable materials and where flammable materials are stored.



Risk of burns due to hot enclosure parts

Mount the inverter in such a way that it cannot be touched inadvertently.

- All electrical installations shall be done in accordance with the local and national electrical codes. Do not remove the casing. Inverter contains no user serviceable parts. Refer servicing to qualified service personnel. All wiring and electrical installation should be conducted by a qualified service personnel.
- Carefully remove the unit from its packaging and inspect for external damage. If you find any imperfections, please contact your local dealer.
- Be sure that the inverters connect to the ground in order to protect property and personal safety.
- The inverter must only be operated with PV generator. Do not connect any other source of energy to it.
- Both AC and DC voltage sources are terminated inside the PV Inverter. Please disconnect these circuits before servicing.
- This unit is designed to feed power to the public power grid (utility) only. Do not connect this unit to an AC source or generator. Connecting Inverter to external devices could result in serious damage to your equipment.

- When a photovoltaic panel is exposed to light, it generates a DC voltage. When connected to this equipment, a photovoltaic panel will charge the DC link capacitors.
- Energy stored in this equipment's DC link capacitors presents a risk of electric shock. Even after the unit is disconnected from the grid and photovoltaic panels, high voltages may still exist inside the PV-Inverter. Do not remove the casing until at least 5 minutes after disconnecting all power sources.
- Although designed to meet all safety requirements, some parts and surfaces of Inverter are still hot during operation. To reduce the risk of injury, do not touch the heat sink at the back of the PV-Inverter or nearby surfaces while Inverter is operating.

3.2 Selecting the Installation Location

This is guidance for installer to choose a suitable installation location, to avoid potential damages to device and operators.

- 1) The wall selected to install the inverter must be strong and firm enough to support and bear the weight of the inverter for a long period time. (Refer to Chapter 11 Specifications)
- 2) The location selected must be suitable for inverters' dimension. (Refer to Fig 3.2 Required Clearances)
- 3) Do not install the inverter on structures constructed of flammable or thermo labile materials.
- 4) Never install the inverter in environment of little or no air flow, nor dust environment.
- 5) The Ingress Protection rate is IP65 which means the inverter can be installed outdoors and indoors.
- 6) Do not expose the inverter to direct sunlight, in order to avoid the power and efficiency derating caused by excessive heating.
- 7) The humidity of the installation location should be 0~95% without condensation.
- 8) The ambient temperature of the inverter should be $-25\text{ }^{\circ}\text{C}\sim+60\text{ }^{\circ}\text{C}$.
- 9) The installation location must be freely and safely to get at all times.
- 10) Vertically installation and make sure the connection of inverter must be downwards. Never install horizontal and avoids forward and sideways tilt.(Refer to drawings below)

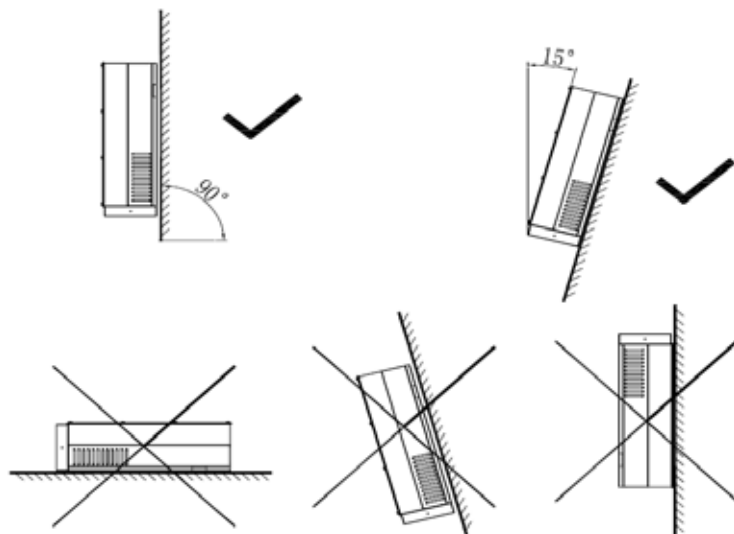

Fig3.1

11) Notice the minimum clearances of the inverter. (Refer to Fig 3.2 Required Clearances).

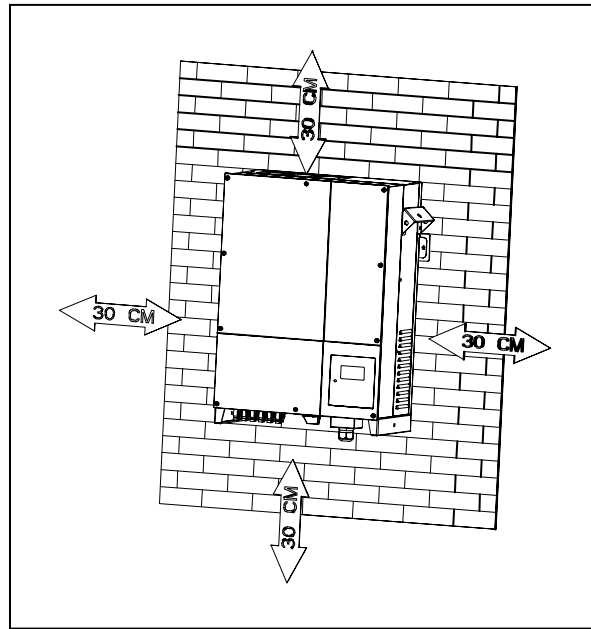

Fig3.2

- 12) Do not install the inverter near television antenna or any other antennas and antenna cables.
- 13) Do not install the inverter in living area, the noise caused by the machine may affect on daily life.
- 14) For security reasons, don't install the inverter in place where the children can reach.

3.3 Installation guidance

3.3.1 Mounting the Bracket



DANGER

In order to avoid electrical shock or other injury, inspect existing electronic or plumbing installations before drilling holes.

To mount the inverter on the wall, we should mount the bracket to the wall firmly first of all

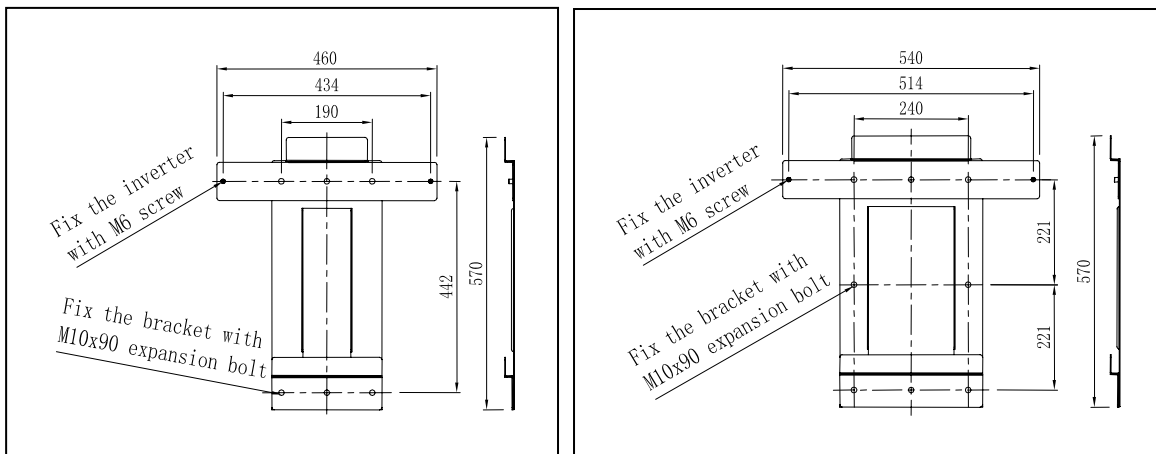

a) Bracket of CHPI 10KTL/12KTL

b) Bracket of CHPI 18KTL/20KTL

Fig3.3

Hint: Data units in mm

Steps:

- Drill holes for screws while use the mounting frame as template.6 holes for CHPI 10/12KTL and 8 for CHPI 18/20KTL.
- Fix the mounting frame on the wall as the figures shown below, combine as the screws as the Items Fig 2.1 shows (items D)

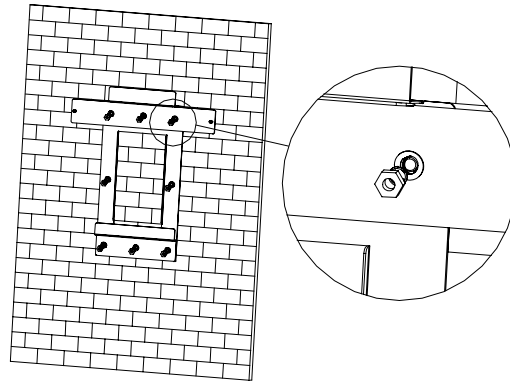

Fig 3.4

3.3.2 Mounting Inverter



DANGER

Falling equipment can cause serious or even fatal injury, never mount the inverter on the bracket unless you are sure that the mounting frame is really firmly mounted on the wall after carefully checking.

After the bracket is firmly mounted on the wall, then mount the inverter on the bracket.

- Rise up the CHPI KTL a little higher than the bracket. Considering the weight of CHPI KTL, you need to hang on the inverter. During the process please maintain the balance of the CHPI KTL.
- Hang the inverter on the bracket through the match hooks on bracket and the back of the inverter.
- Installed one M6*10 screw at each side of inverter to reliable fixed it on the wall. Please reference in Fig3.5(b).
- Connect the inverter to the earth. Please reference in Fig3.6.
- Recommend awning installation, the purpose is to extend the inverter service life and reduce the power derating of the inverter. The dimensions of awning refer to Fig 3.8.

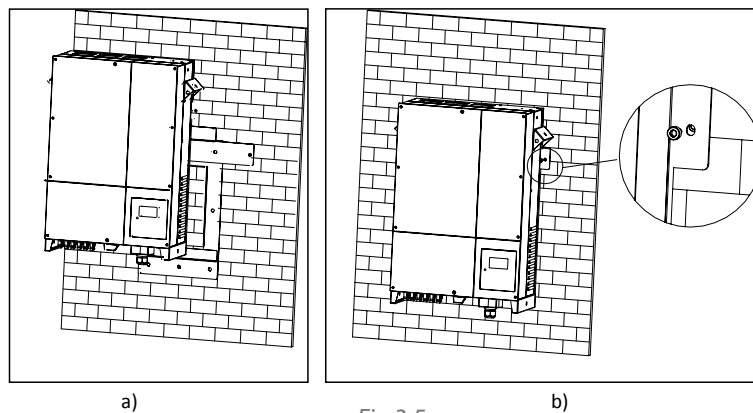

Fig 3.5

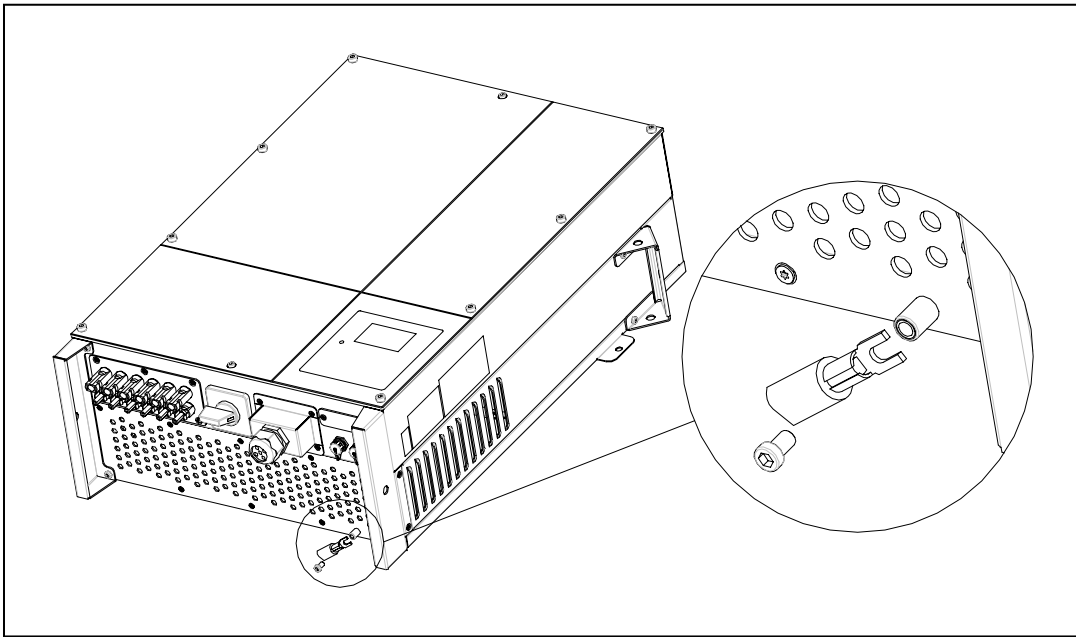

Fig 3.6

3.3.3 Installation layout



Information

Avoid exposing inverter to direct sunlight, rain or snow to extend the inverter service life despite the IP65 protection degree. Exposure to the sunlight may cause additional internal heating which will cause power derating.



Fig 3.7

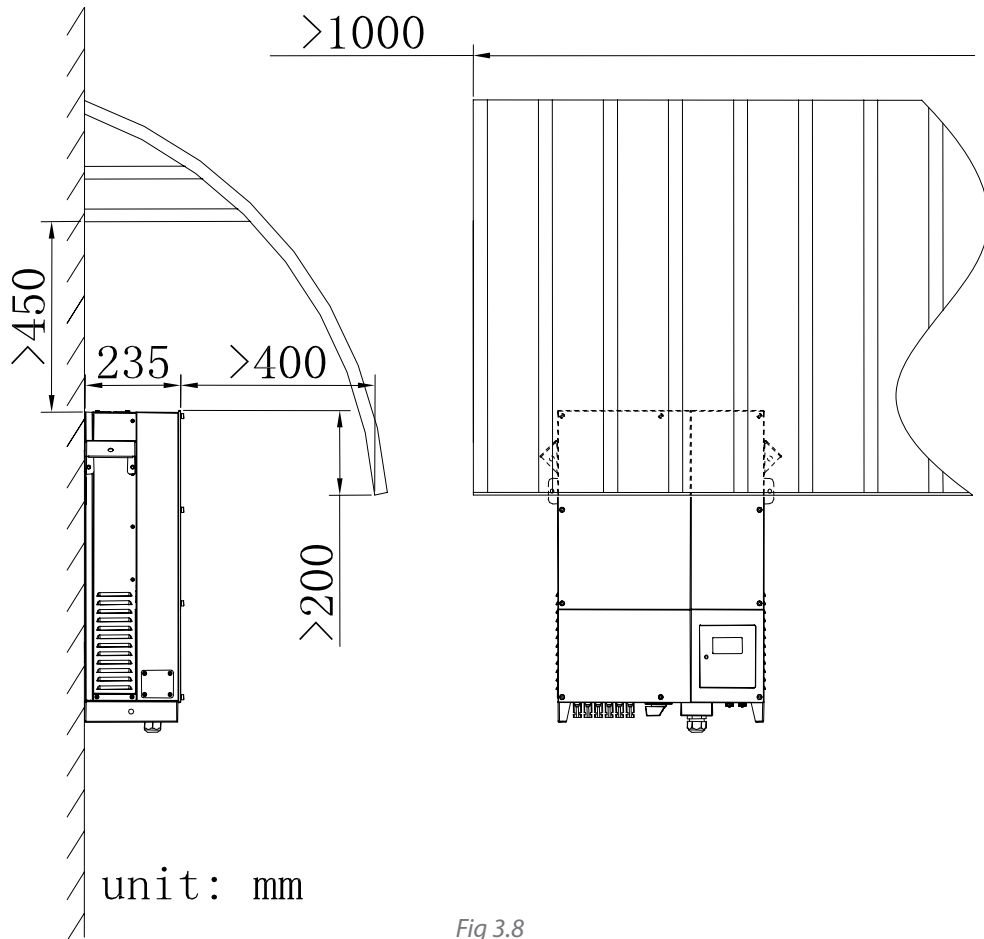

Fig 3.8

More than one inverter need to be installed, the dimensions below should be considered.

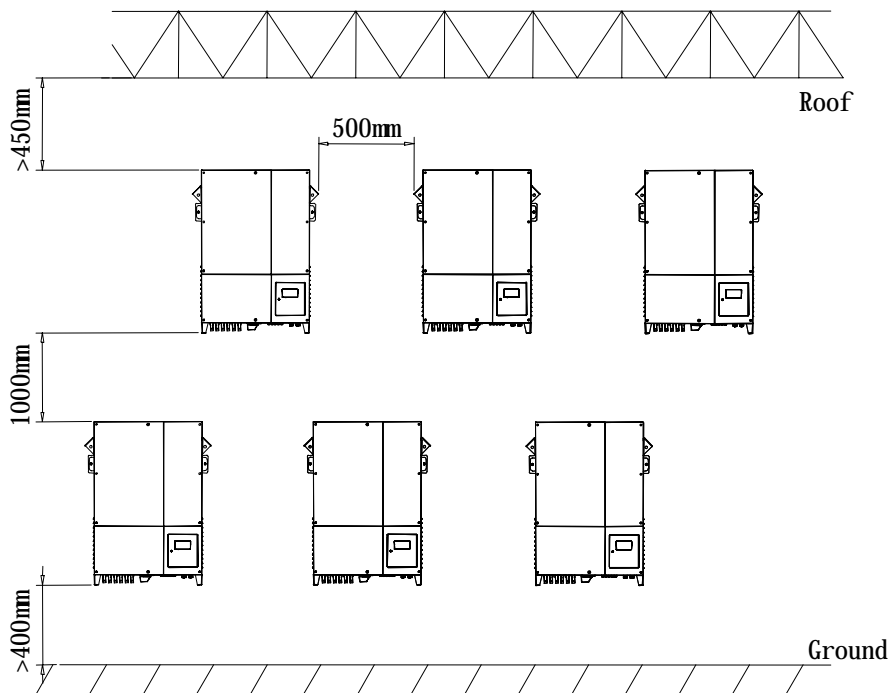
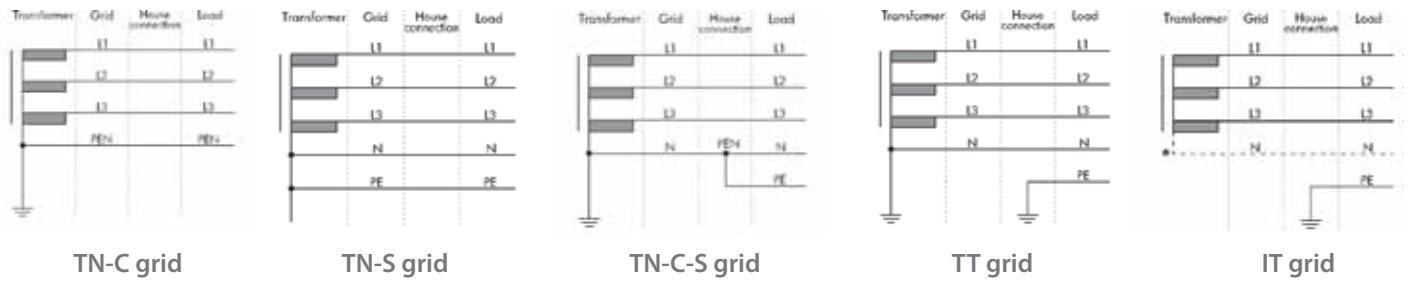

Fig 3.9

4. Electrical Connections

4.1 Types of Grid Structure and Connection Compatibility

Grid type



Types	TN-C grid	TN-S grid	TN-C-S grid	TT grid	IT grid
CHPI 10KTL	yes (N and PE of inverter both should connect to PEN of grid.)	yes	yes	yes, if $U_{N-PE} < 30V$	no
CHPI 12KTL	yes (N and PE of inverter both should connect to PEN of grid.)	yes	yes	yes, if $U_{N-PE} < 30V$	no
CHPI 18KTL	yes (N and PE of inverter both should connect to PEN of grid.)	yes	yes	yes, if $U_{N-PE} < 30V$	no
CHPI 20KTL	yes (N and PE of inverter both should connect to PEN of grid.)	yes	yes	yes, if $U_{N-PE} < 30V$	no

4.2 Wiring AC Output

You must install a separate three-phase circuit-breaker or other load disconnection unit for each inverter in order to ensure that the inverter can be safely disconnected under load.

- Measure the public grid voltage and frequency (Voltage: 400Vac; Frequency: 50Hz; in 3-Phase);
- Open the breaker between the PV inverter and utility;
- Screw's torsional force is 8 kg/cm;

* Specification of AC breaker: CHPI 10KTL/12KTL:25A/400V CHPI 18KTL/20KTL:50A/400V

Cable requirements:

Model	Diameter(mm)	Area(mm ²)	AWG
10KTL	2.05~4.11	4~16	12~6
12KTL	2.05~4.11	4~16	12~6
18KTL	2.59~4.11	6~16	10~6
20KTL	2.59~4.11	6~16	10~6

Conductor cross section	Max. cable length			
	CHPI 10KTL	CHPI 12KTL	CHPI 18KTL	CHPI 20KTL
6.0 mm ²	53m	44m	29m	26m
10.0 mm ²	88m	73m	49m	44m
16.0 mm ²	141m	116m	78m	71m

AC connector type	Available wire gauge
AC Screw Terminal	6.0-16.0 mm ²

AC Screw Terminal:

1. The AC side terminals of the inverter are like the following figure, it is clear to confirm that 'L1, L2, L3' represents three live line output, 'N' represents neutral line and '⏏' is grounding line.

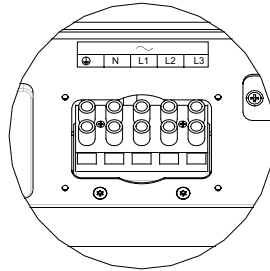

Fig 4.2.1

2. Connect five standard cables into relevant terminals. The five cables should be put through the protection shell, as figure below.

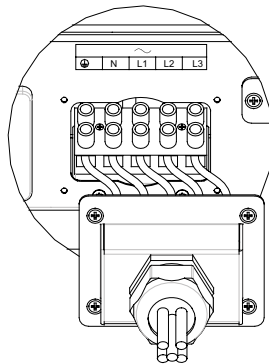

Fig 4.2.2

3. Fasten the protection shell onto the bottom of the inverter, make sure the four screws are tight, the completed appearance is like the below figure.

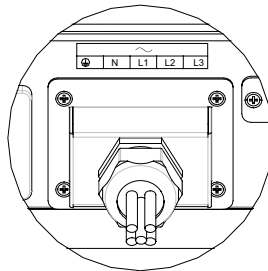

Fig 4.2.3

4.3 Wiring DC Input

- 1 Check the connection cables of the PV modules for correct polarity and make sure that the maximum input voltage of the inverter never exceed 1000Vdc.
- 2 The diagram drawing of DC side is shown as below, notice that the connectors are in paired (male and female connectors). The connectors for PV arrays and inverters are H4 (AMPHENOL) connectors;

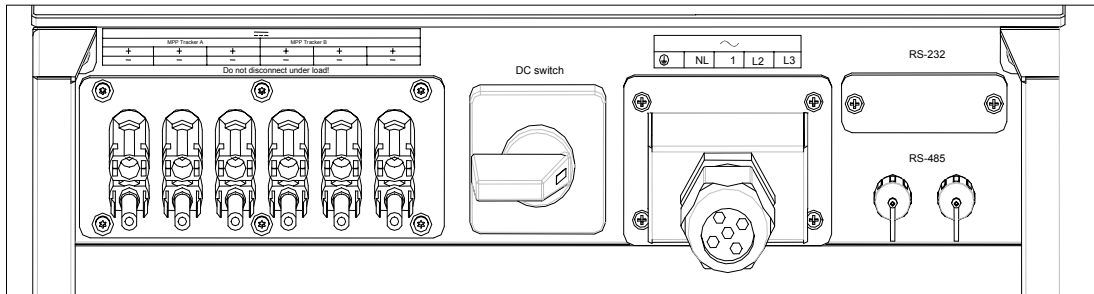

Fig 4.3.1

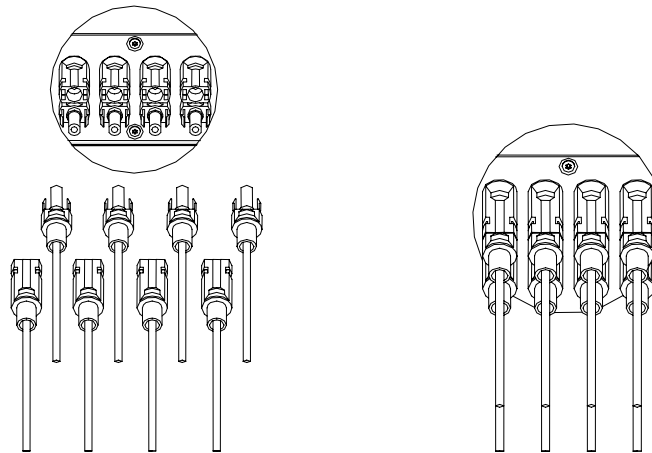

Fig 4.3.2

- 3 Check the assembled DC connectors for correct polarity and connect them to the inverter.
- 4 The maximum string currents are varying from different inverter types.

Type	Max.current
10KTL	15A
12KTL	17A
18KTL	23A
20KTL	26A

5 Cable requirements:

Model	Diameter(mm)	Area(mm ²)	AWG
10KTL	2.05	3.332	12
12KTL	2.05	3.332	12
18KTL	2.05	3.332	12
20KTL	2.05	3.332	12

4.4 RS485 cable connection

Type 1:

1. Unscrew the plastic connector.

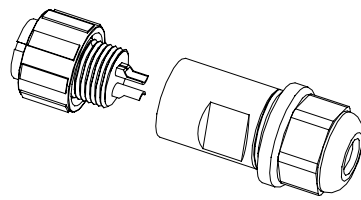

2. Make the RS485 cable go through the connector.

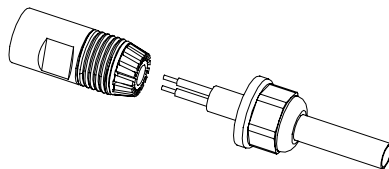

3. Put two heat shrink tubes onto the front head of RS485 cable.

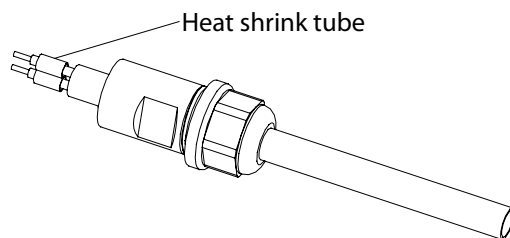

4. Insert the two metal head into relevant small cupreous hole, and fasten the connection by soldering.

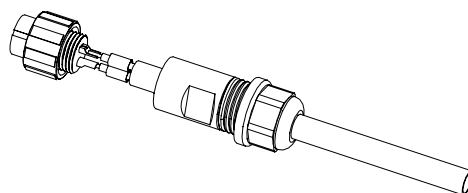

5. Make the heat shrink tubes wrap the joint.

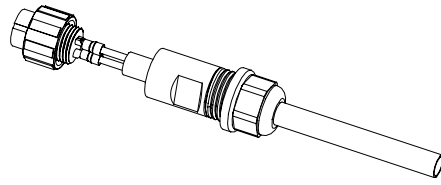

6. Assemble the connector.

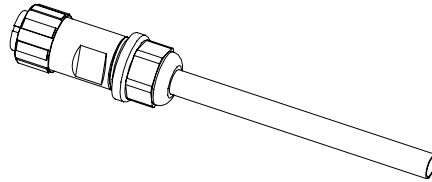

7. Connect the RS485 connector onto the inverter. Make sure the connection matched ('1' to '1'; '2' to '2').

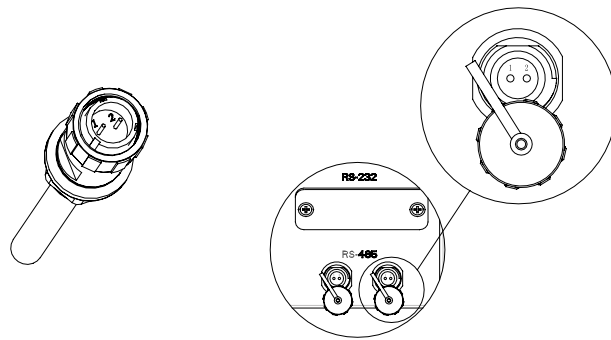

Type 2:

1. Please loosen four screws, take down the RS485 waterproof cover from inverter. If you don't choose RS485 as communication method, keep it on the inverter.

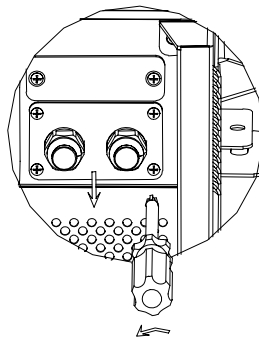

2. Slightly loosen the swivel nut, remove the filler-plug from the M16 cable gland.

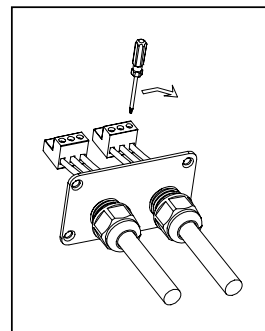
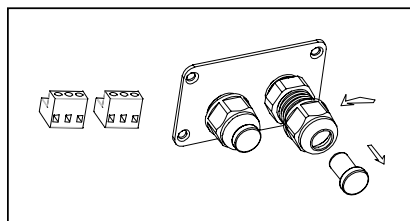

3. Make the cable through the hole of cable gland and put the cable into the RS485 terminals, fix all cables with screwdriver ('1'to'1','3'to'3','2'to the shielding layer or no connection.). The type of cable is recommended as "KVVRP22/2*1.5mm2".



Information

Pull cables outwards to confirm whether they are installed firmly

4. Plug in two terminals. Cover the fix board.

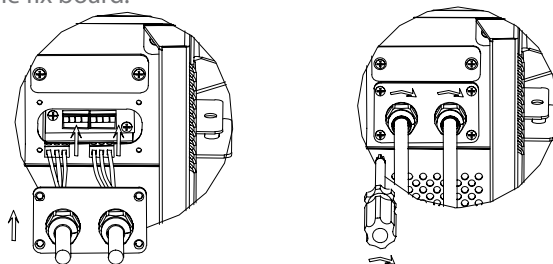

Information

Tighten 4 pcs screws first, then tighten cable gland.

5. Tighten 4pcs screws and cable gland.

Note:

1) As to the connection between inverters, please refer to the following figure.

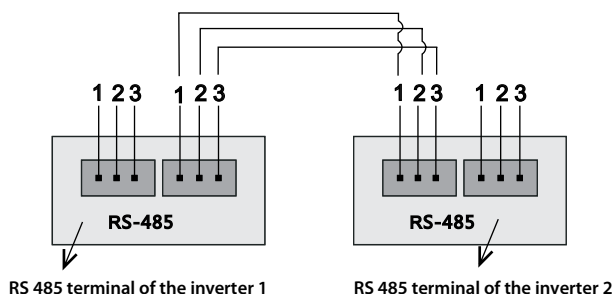

2) As to the connection between inverter and ShineWebBox (ShinePano), please refer to the following figure.

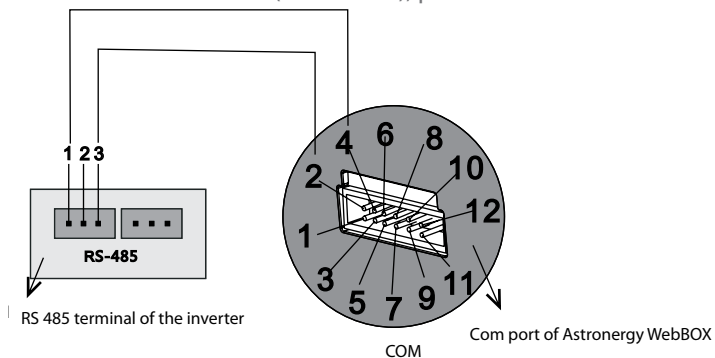

5. Heat Dissipation Maintenance

Heat dissipation is important to reduce the power derating when Astronergy inverters working under high ambient temperature. Astronergy inverters are equipped with cooling fans on the top of the shell. When the temperature is high, fans start work to lower the ambient temperature.

Once the output power is derating because of too high warming, some tips can help you solve such problems:

- The air grills or cooling fans are clogged.
To clean the air grills and cooling fans please refer to 5.1 Cleaning Fans and Grills.
- One or two cooling fans failed.
To exchange the cooling fans please refer to 5.2 Exchanging Fans.
- Poor ventilation of installation location.
Choose appropriate installation location before mounting.

5.1 *Cleaning Fans and Grills*

Maintain fans and grills every half a year to reduce the power derating caused by high warming.

If the fans or grills are just covered by soft dust particles, using tools such as vacuum cleaner to clean the fans. And if user has no such tools or there are obstructions in fans, grills or the cooling area of inverter, you need to clean the fans and grills after they are took apart from the inverter.

1. Please disconnect the DC and AC connection.

- Turn off the DC switch.
- Disconnect the DC terminal. (You might need some tool to disconnect the male and female terminals)
- Disconnect the AC terminal.

2. Remove the protecting plants at the bottom of CHPI KTL inverter.

Remove the inverter from mounting bracket, and place inverter horizontally on clean and dry place.

3. Screw off the screws to open the cover with suitable tool, then fans will be seen, as figures below:

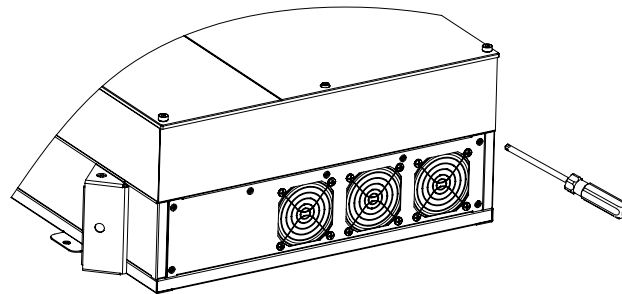

Fig 5.1.1

4. Pull out the white connectors with some tinny tools.

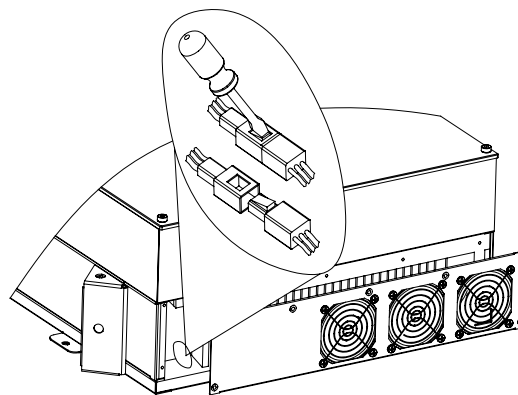

Fig 5.1.2

5. Take away the fans from the cover and clean them thoroughly.

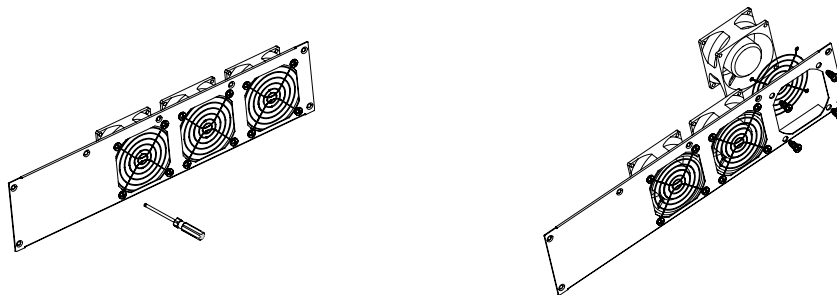

Fig 5.1.3

6. When finishing cleaning, put back the fans in reverse order.

5.2 Exchanging Fan

Sometimes the heat dissipation error occurred because the cooling fans failed, under such circumstances, one need exchange the cooling fans.

6. Commission the Inverter

1) Remove all covers from the PV array.

2) Check the PV and AC voltage.

3) Plug in the PV input.

4) Turn the DC Disconnect to position "I".

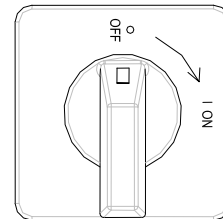

Fig 6.1

5) If the inverter is connected with PV panel arrays and the input voltage is higher than 300Vdc, while the AC grid is not connected yet, LCD will display messages in order as below:

- Company info ➔ Basic info ➔ State info
- The LCD will display " AC V outrange "at State info and the LED turns red.
- Please check all information on the LCD, operate by knocks you will see the different parameters.
- Single knock to Light the backlight ➔ State info (single knock) Input info ➔(single knock) Output info

6) Turn on the AC breaker between inverter and grid, the system will operate automatically.

7) Under normal operating conditions, the LCD displays 'Power: xx.xx Kw' at State info, this is the power feed into grid. The LED turns green.

8) Check the time and date of inverter as follow:

Single knock to Light the backlight ➔ State info (Thrice knock) ➔ Inverter info (single knock) ➔ System Time(double knock), if they are not correct, please set them, refer to 6.3.4 or 6.4.3 text line.

9) Finish commissioning.

7. Operation Modes

7.1 Normal Mode

In this mode, the inverter works normally and LED turns green.

- Whenever the DC voltage is higher than 350Vac, inverter converts power to grid as generated by the PV panels;
- Whenever the DC voltage is lower than 300Vac, the inverter will work in waiting state and attempt to connect the grid. In waiting state the inverter consumes just enough power generated by the PV panel to monitor the internal system

Notes: The inverter starts up automatically when DC power from the PV panel is sufficient.

7.2 Fault Mode

The internal intelligent controller can continuously monitor and adjust the system status. If inverter finds any unexpected conditions such as system fault and inverter fault, the fault information will be displayed on the LCD. In fault mode the LED turns red.

Notes: Detailed fault information refers to Chapter 10.2 ERROR messages displayed on LCD.

7.3 Shutdown Mode

Inverters automatically stop running during periods of little or no sunlight. In shutdown mode the inverters take no power from the grid and panel, and the LCD and LED turns off.

Notes: If the PV string DC voltage is too low, the inverter will also turn to Shutdown Mode.

8. Country Setting and LCD Display

In the lower right corner of inverter there is the LCD display. We can check inverter running status, historical generation data, etc, on the LCD screen. Items displayed can be changed by knock; you can also change some inverter parameters by knock.

8.1 Country Setting

If it is the first time the inverter starts up after installation, LCD will quickly switch to and stay at the country setting interface. Only the inverter is set to comply with a certain country rule, it will work and display normally. Otherwise, LCD will always stay at the 'Please select' interface.

Please finish the country setting according to the following steps:

1. When at the first interface 'Select country :', the option is 'VDE0126' in default. By single knock, countries will vary from one to another, for example, 'France', as Fig 8.1.2.

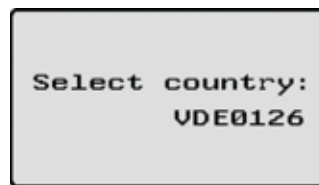

Fig 8.1.1



Fig 8.1.2

* If you have ordered the inverter with specific country settings, the parameters have been preset in factory and you don't need to operate this step any more.

2. There are eleven countries/rules to select:

1	VDE0126
2	Germany
3	France
4	Italy
5	Greece
6	Hungary
7	Belgium
8	Turkey
9	Denmark
10	Spain
11	UK-G59

Note: if you can't find the country you want, please directly select 'VDE0126'.

3. When it comes to the country you want, double knock to enter, as Fig 03.

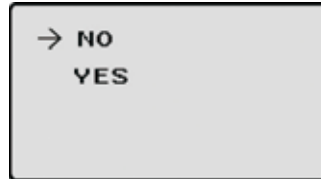

Fig 8.1.3

4. When enter the confirm interface, there are two options 'NO' and 'YES', and the cursor will stay at 'NO' in default, single knock to shift between 'NO' and 'YES', double knock to confirm your selection. When at 'NO', double knock will exit, when at 'YES', double knock will set up. After the setting is successful, the LCD will display 'Set Country OK', and inverter will reboot automatically.



Fig 8.1.4

8.2 Power on Display

8.2.1 Power on display

After inverter restarts, LCD background will light automatically. Astronergy Logo will appear immediately. The background light will last for 2 seconds. See Fig8.2.1 for reference.

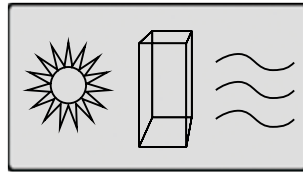

Fig8.2.1:Power on Astronergy Logo

After displaying Astronergy Logo for 2 seconds, LCD screen will switch to the second interface, display the figure of inverter, company name, inverter's power rating, etc. The second interface will last for 3 seconds. See Fig8.2.2 for reference.

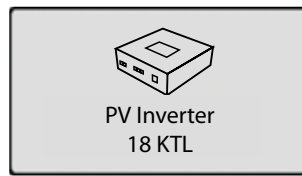

Fig 8.2.2:The second power on interface

After 3 seconds, it will switch to the third interface. See Fig8.2.3 for reference.

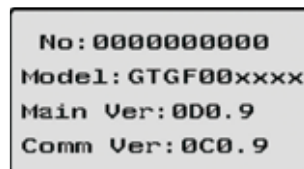

Fig8.2.3:The third power on interface

Here are explanation of items on Fig8.2.3:

No. : serial number of this inverter.

Model:model name of this inverter.

Main Ver: firmware version of control board

Comm Ver: firmware version of communication board .

After displaying information of the third interface for 3 seconds, the background light will turn off.

LCD Display Overview

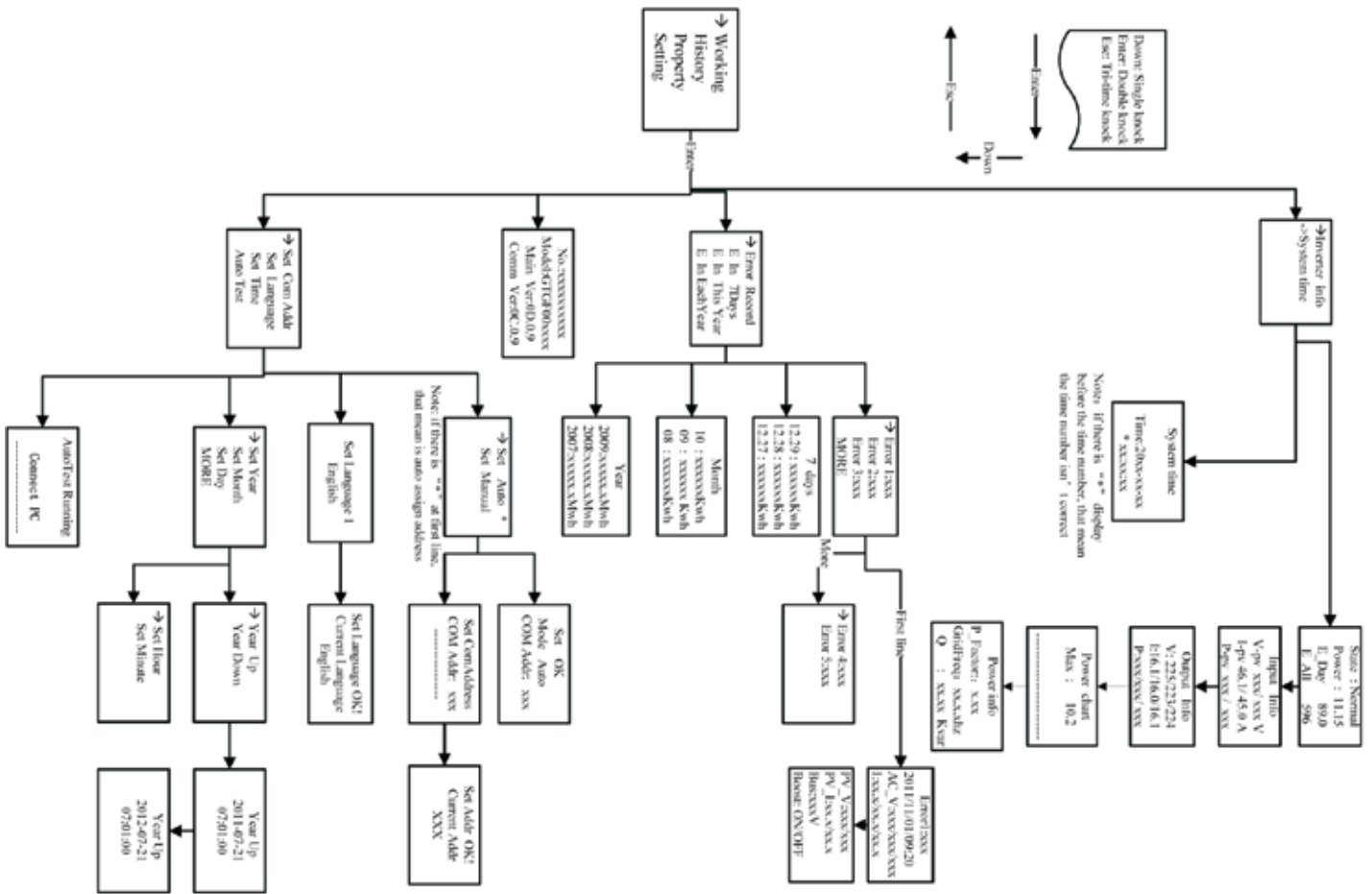

8.2.2 LCD Display when background light off

After the power on information is displayed automatically and the background light turns off, the LCD display will switch to the following Interface 1. There are 4 interfaces, which can be displayed in turn by single knock.

Interface 1: Running status. See Fig 8.2.4 as reference. The first line displays inverter's status description, for example, in faulty state it will display ERROR and followed with faulty codes, which is convenient to compare with error code list in manual. The second line displays inverter's states name; and the third line displays energy generated today, and the forth line displays the total energy generated since installation.

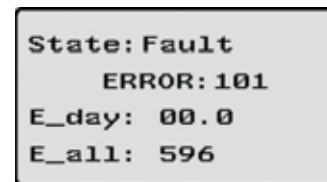

Fig8.2.4:Interface 1: Running status

Interface 2: Input information. See Fig8.2.5 for reference.

This interface displays parameters of PV input, including input voltage, current, and power of each MPP tracker

V-pv: input voltage of MPPT1 and MPPT2

I-pv: input current of MPPT1 and MPPT2

W-pv: input power of MPPT1 and MPPT2

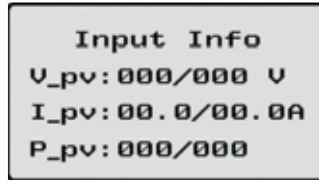

Fig8.2.5:Interface 2: Input information

Interface 3: Output information. See Fig8.2.6 for reference.

This interface displays output information of inverter, including output voltage of each phase, output current of each phase, and output power of each phase.

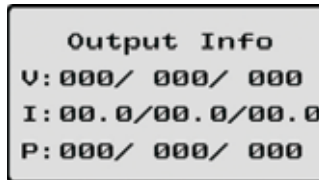

Fig8.2.6:Interface 3: Output information

V: output voltage of each phase

I: output current of each phase

P: output power of each phase

Interface 4: 24 hour' generation curve. See Fig8.2.7 for reference.

This interface shows the generated power of every hour this day.

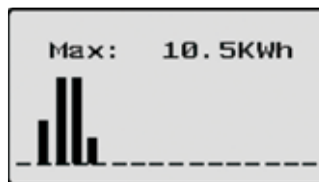

Fig8.2.7:Interface 4: 24 hour's generation curve

Max: maximum power of today

Power curve: today's power curve

8.2.3 Connecting messages

When inverter started to connect to grid, the following message will appear on LCD screen. See Fig8.2.8 for reference.

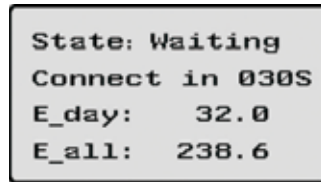

Fig8.2.8 Connect to gird interface

8.3 Operate by knock

8.3.1 Knock type and definition

The inverter can support three kinds of knock: single knock, double knock and thrice knock. Each kind of knock has different function. Refer to specified definition in Table 8.1.

Table 8.1 Knock definition list

Knock type	Definition
Single knock	Down
Double knock	Enter
Tri - three knock	Esc
Knock four times	Unlock LCD

8.3.2 Light background light and single knock to check running information

Before light the background light, the three types of knock functions the same, which is just lighting the background.: just light the background . Note that the background lighting will automatically turn off if there is no knock detected in 10 seconds.

During cloudy days or in the area of low light, it's inconvenient for users to check inverter running information such as status, input data, output data, energy generated. In this case user can light the background and check those data by single knock, a single knock will switch LCD screen to a following interface. The interface display on LCD screen will circle as follows: Fir8.2.4 -> Fig8.2.5 -> Fig 8.2.6 -> Fig8.2.7 -> Fig8.2.8, and then again Fig8.2.4.

8.4 Data checking and parameters setting

8.4.1 First level menu

It is a little bit different to enter the first level menu, note that using thrice knock to enter first level menu instead of double knock. Fig 8.4.1 is interface of first level menu.

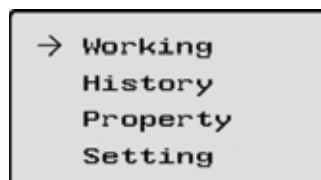

In this interface, a single knock will switch the index to next item, a double knock will enter the corresponding second level menu.

8.4.2 Second level menu

In first level menu, double knock will lead to next level menu.

The followings are second level menu interfaces for each first level menu items, shown in Fig 8.4.2

In second level menu, a single knock will switch the index to next item, a double knock will enter the corresponding third level menu. And a thrice knock will back to first level menu.

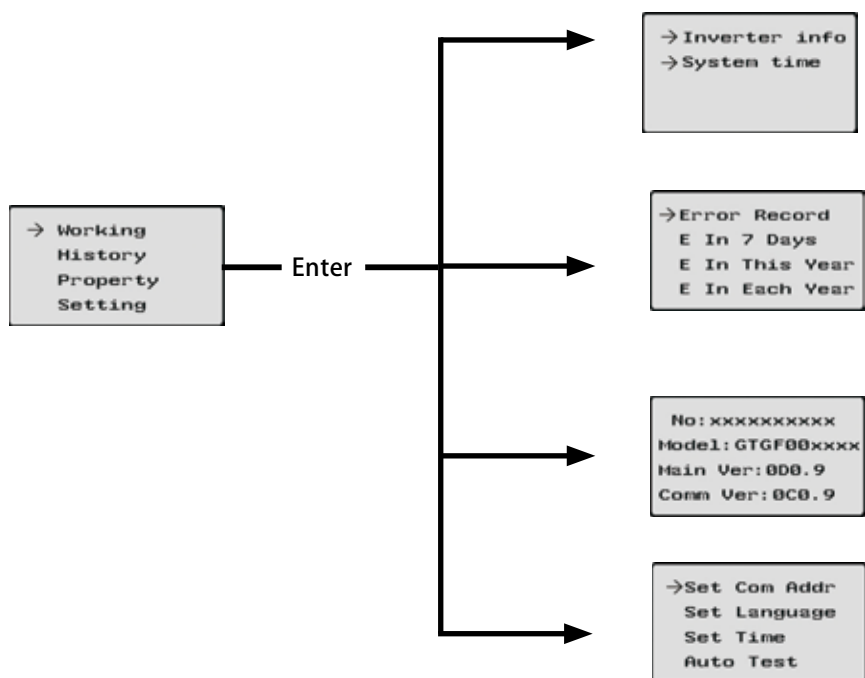

Fig 8.4.2 Second level menu for each first level menu items

8.4.3 Third level menu and explanations

8.4.3.1 Working information

The followings are third level menu interfaces for each second level menu items of working information, shown in Fig 8.4.3.

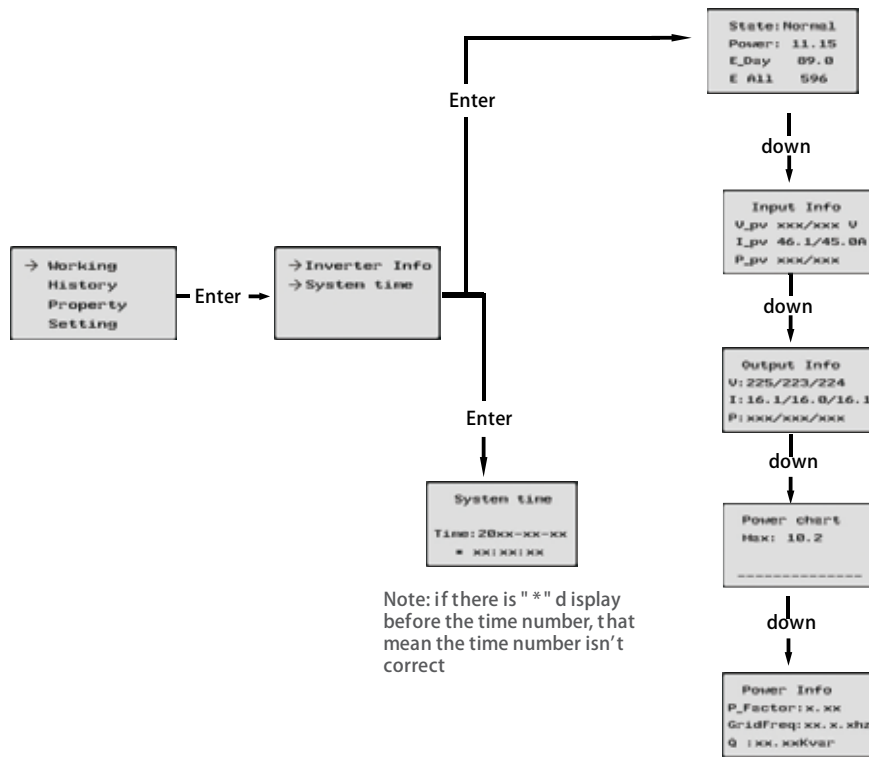

Fig 8.4.3 Third level menu interface of working information

Explanations of each items in third level menu interface of working information: State information:

Table 8.2 Working information sub-items explanation

Second level menu	Third level items	Item explanation
Inverter info	State: Normal	Inverter running status
	Power: xxx.xx	AC gross output power
	E_day	Energy produced today
	E_all	Energy produced since installation
	Input info	Inverter input parameters
	V-pv xxx/xxx	PV input voltage for each MPP tracker
	I-pv xx.x/xx.x	PV input current for each MPP tracker
	P-pv xxx/xxx	PV input power for each MPP tracker
	Output info	Inverter output parameters
	V: xxx.xxx.xxx	AC output voltage for each phase
	I: xx.x/xx.x/xx.x	AC output current for each phase

Second level menu	Third level items	Item explanation
Inverter info	P: xxx/xxx/xxx	AC output power for each phase
	Power chart	histogram of generation power
	Maxrve	Maximum output power of inverter
	Power info	Generation power information of inverter
	P_Factor	Power factor
	Q	Reactive power
	GridFreq	Utility grid frequency

8.4.3.2 Historical information

The followings are third level menu interfaces for each second level menu items of historical information, shown in Fig 8.4.4.

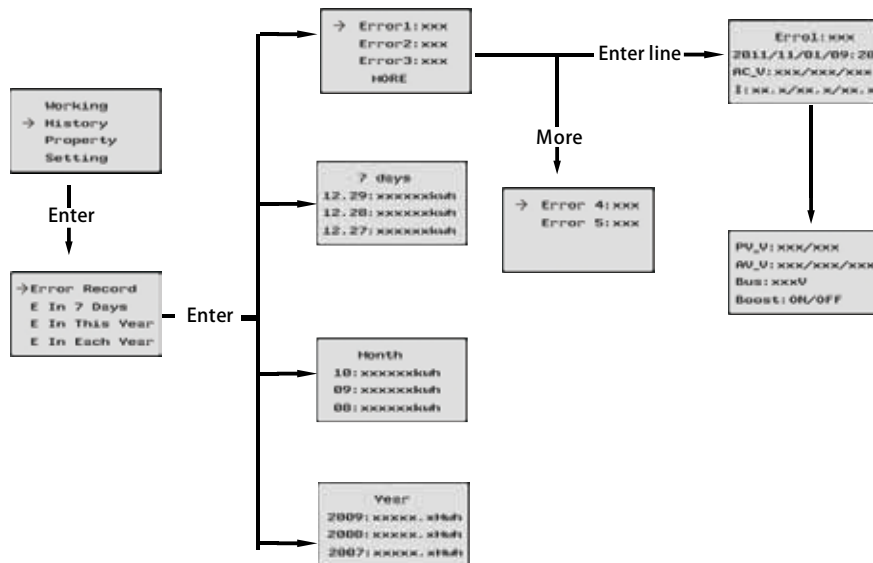

Fig 8.4.4 Third level menu interface of historical information

Explanation of each items in third level menu interface of working information: State information:

Table 8.3 Historical information sub-items explanation

Second level menu	Third level items	Item explanation
Error Record	Error1: xxx	Five latest error records
	Error2: xxx	
	Error3: xxx	
	Error4: xxx	
	Error5: xxx	
	More	More error record

Second level menu	Third level items	Item explanation
E in 7Days	7 Days	Title indicate this is latest 7 days running data
	MM:DD: xxxx.x Kwh	Format is Month:Date, xxxx.x is energy generated in that day.
E in Each Month	Month	Title indicate this is every month's running data in this year
	MM: xxxx.x Kwh	xxxx.x is energy generated in that month.
E in Each Year	Year	Title indicate this is latest 10 years running data
	20XX: xxxx.x Mwh	xxxx.x is energy generated in the corresponding year.

8.4.3.3 Property information

The followings are second level menu interfaces of property, shown in Fig 8.4.5.

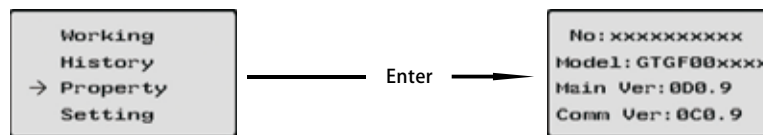

Fig 8.4.5 Property information

Explanation of each items in third level menu interface of working information: State information:

First level menu	Second level items	Item explanation
Property	No.:xxxxxxx	Serial number of this inverter
	Model:GTGF00xxxx	Model name of this inverter.
	Main Ver:0D0.9	Firmware version of Control Board
	Comm Ver:0C0.9	Firmware version of Communication Board

8.4.4 Parameters set and auto test

The followings are setting information in second level menu and its submenus, shown in Fig 8.4.6.

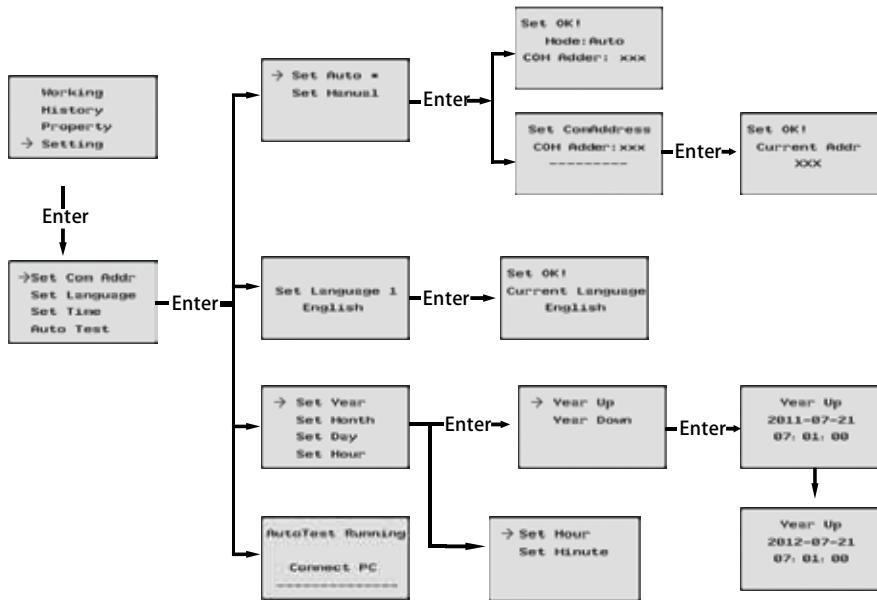

Fig 8.4.6 setting second level menu and its sub-menus

8.4.4.1 Set inverter's COM address

When communicating with monitoring software or device, the software or device may regard inverter's COM address as communication address (Also may use inverter's serial number as communication address).The COM address could be assigned. The second level menu "Set COM Addr" of setting is to set inverter's COM address. Set fixed COM address:

Input password->Setting->Set COM addr->Set Manual, "Current Addr" is the current address of inverter."COM Addr Up"add address. "COM Addr Up" decrease address .Single knock to change value of fixed address, double knock enter next manual. Choose "YES"to save changes, and LCD screen will display "Set Addr OK! Current Addr XXX", see Fig 8.4.6 for reference.

8.4.4.2 Set language

To change inverter's displaying language, please select Setting->Set language, then LCD screen will display current language type, single knock to change current language, double knock will save changes and displays "Set Language OK! Current Language English" see Fig 8.4.6 for reference.

The inverter provides five languages: Italian, English, German, Spanish, and French. The number on Set language interface is sequence number of these five languages, the sequence number and its corresponding language are shown in Table 8.5

Table 8.5 sequence number of languages

Language	Sequence Number
Italian	0
English	1
German	2
Spanish	3
French	4

8.4.4.3 Set inverter time

Inverter provides a system clock; user must set the system time after installation, as the historical statistic data for a period were based on the clock. User can set the following time parameters: year, month, day, hour, minute.

Set year: Setting->Set time->Set year->Year up or Year down->knock to change year. Thrice knock to exit and save changes.

Set month: Setting->Set time->Set month->Month up or Month down->knock to change month. Thrice knock to exit and save changes.

Set date: Setting->Set time->Set date->Date up or Date down->knock to change date. Thrice knock to exit and save changes.

Set hour: Setting->Set time->Set hour->Hour up or Hour down->knock to change Hour. Thrice knock to exit and save changes.

Set minute: Setting->Set time->Set minute->minute up or minute down->knock to change minute. Thrice knock to exit and save changes.

8.4.4.4 Auto test function

Auto test function is to check the inverter's protection when grid is abnormal, including over voltage, under voltage, over frequency, and under frequency.

To run auto test function please select Setting->Auto test, then double knock to start auto test function. It's required to connect inverter to computer and run a test software in computer.

Auto test procedure

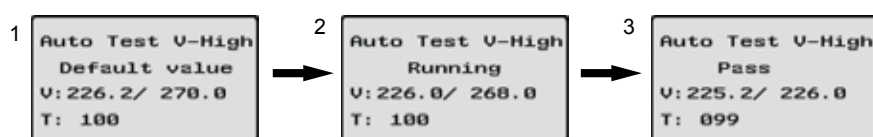

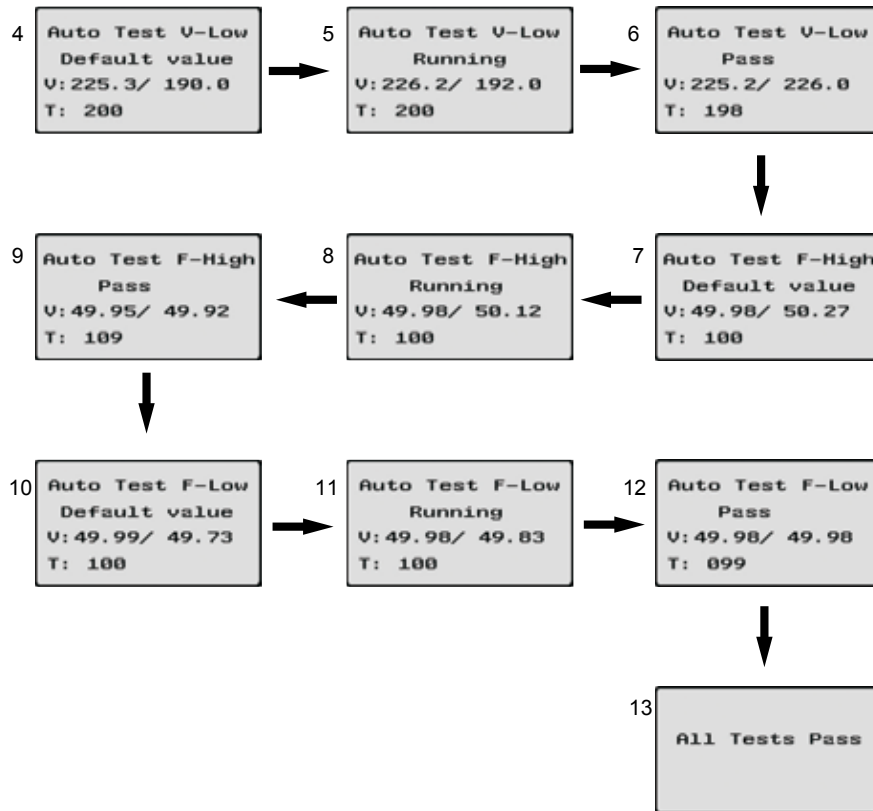

Fig 8.4.7

8.5 Inverter faulty messages

When system fault or inverter error occurs, inverter will display faulty message or error code on LCD screen.

8.5.1 System fault

System fault is related to the solar system, it may be caused by PV panels wiring, AC wiring, or AC grid faults.

The followings are all system faulty messages displayed on inverter:

System fault message may display on LCD	Explanation and suggestion
Auto Test Failed	Auto test didn't pass
No AC Connection	No utility, no grid connected
PV Isolation Low	Insulation problem
Residual I High	GFCI current high
Output High DCI	Output current DC offset too high

System fault message may display on LCD	Explanation and suggestion
PV Voltage High	PV panel voltage too high
AC V Outrange	Grid voltage out of range
AC F Outrange	Grid frequency out of range

8.5.2 Error message

Inverter errors are problems come from interior inverter.

ERROR CODE	OPERATION
Error: 100	Fan fault
Error: 101	Communication fault
Error: 103	EEPROM fault
Error: 104	Model Fault
Error: 117	Relay Fault
Error: 119	GFCI Fault
Error: 121	Control board communication Fault

9. Communication

9.1 AstronergyNet

AstronergyNet is a monitoring software applied to monitor Astronergy inverters via RS232 port or Bluetooth module. With the special designed functions and friendly compact UI, it can comprehensively meet users' requirements for system monitoring and bring unprecedented user experience.



Fig 9.1

Features:

- Monitor and record current data and of inverters.
- Record historical data.
- Monitor and record event information of inverter.
- Connect computer and inverter via RS232 and RS485 port (wire connection) or Bluetooth module (wireless connection).
- Remote access available for local area network

Notes: Users are able to monitor the inverter after the setting of software. Detailed information about setting and functions refer to the AstronergyNET Manual.

9.2 AstronergyVision

AstronergyVision is a wireless monitoring device, which consists of a power monitor and a number of transmitters, and one AstronergyVision can monitoring 1 to 6 inverters. The transmitters transmit the running data collected from photovoltaic inverters to the monitor and display the data onto the monitor screen, including data of generated energy, the gross generated energy and the generation income obtained from the above-mentioned data through some simple calculations, indoor temperature, date and time, as well as CO2 emissions.

Features:

- Monitor and transmitter communicate via wireless communication technology
- External transmitter, with IP65 waterproof and dustproof.
- A monitor can simultaneously communicate with six transmitters.
- Communication distance between monitor and transmitter : 30 meter.
- Power supply option: built-in battery slot, an external DC power supply.
- Easy installation, and convenient to use it.



Fig 9.2

Notes: The Monitor should be kept indoor. For detailed information, please refer to AstronergyVision Manual.

9.3 AstronergyPano

It is the latest intelligent monitoring master, specially designed for solar power plant. Using stable Linux operating system with high-speed CPU, it can smartly present solar system status through friendly user interface on 8-inch large color touch screen.



Fig 9.3

Features:

- A multi-functional and high-performance communication data logger; Keep user informed of the system's status at any time.
- Massive storage with flexible parameters setting, system information management, error prompt and record.
- Collects data and uploads information over the internet in near real-time to Astronergy Server platform.
- Connect with inverter: RS485 and Zigbee (Wireless module).
- 8 inches touch screen(*option): support hand writing and USB mouse.

9.4 AstronergyWebBox

It is a cost-effective and compact monitoring device, specially designed for solar power plant. Using stable Linux operating system with high-speed CPU, it can smartly record your system features. AstronergyWebBox Provides local storage, easy wireless and TCP/IP configuration, and presents plant data over Internet.

Features:

- A multi-functional and high-performance communication data logger; Keep user informed of the system's status at any time.
- Massive storage with flexible parameters setting, system information management, error prompt and record.
- Collects data and uploads information over the internet in near real-time to Astronergy Server platform.



Fig 9.4

10. Trouble Shooting

Our quality control program assures that every inverter is manufactured to accurate specifications and is thoroughly tested before leaving our factory. If you have difficulty in the operation of your inverter, please read through the following information to correct the problem.

10.1 General question

For General question, please visit www.astronergy.com, and find the Q&A column.

10.2 Error Messages displayed on LCD

An error message will be displayed on the LCD screen when a fault occurs. The faults consist of system fault and inverter fault.

You may be advised to contact Astronergy in some situation, please provide the following information.

Information concerning the inverter:

- Serial number
- Model number
- Error message on LCD
- Short description of the problem
- Grid voltage
- DC input voltage
- Can you reproduce the failure? If yes, how?
- Has this problem occurred in the past?
- What was the ambient condition when the problem occurred?

Information concerning the PV panels:

- Manufacturer name and model number of the PV panel
- Output power of the panel
- Voc of the panel
- Vmp of the panel
- Imp of the panel
- Number of panels in each string

If it is necessary to replace the unit, please ship it in the original box.

10.2.1 System fault

System fault (system faults are mainly caused by system instead of inverter, please check the items as instructed below before replacing inverter)

Error message	Description	Suggestion
AC V Outrange	Utility grid voltage is out of permissible range.	<ol style="list-style-type: none"> 1. Check grid voltage. 2. Check AC wiring, especially the ground wire. 3. If the error message still exists despite the grid voltage being within the tolerable range, contact Astronergy.
AC F Outrange	Utility grid frequency out of permissible range.	<ol style="list-style-type: none"> 1. Check AC wiring and grid frequency. 2. If the error message is displayed despite the grid frequency being within the tolerable range, contact Astronergy.
PV Isolation Low	Insulation problem	<ol style="list-style-type: none"> 1. Check if panel enclosure ground properly. 2. Check if inverter ground properly. 3. Check if the DC breaker gets wet. 4. Check the impedance of PV (+) & PV (-) between ground (must be more than 8 MΩ). If the error message is displayed despite the above checking passed, contact Astronergy.
Residual I High	Leakage current too high	<ol style="list-style-type: none"> 1. Restart inverter. 2. If error message still exists, contact Astronergy.
Output High DCI	Output current DC offset too high	<ol style="list-style-type: none"> 1. Restart inverter. 2. If error message still exists, contact Astronergy.
PV Voltage High	The DC input voltage is exceeding the maximum tolerable value.	<ol style="list-style-type: none"> 1. Disconnect the DC wire immediately. 2. Check the voltage of each PV string with multimeter. 3. If the voltage of PV strings are lower than 1000V(+15V), contact Astronergy.
Auto Test Failed	Auto test didn't pass.	Restart inverter, repeat Auto Test, if problem still exist, contact Astronergy.

10.2.2 Inverter warning

Warning code	Meanings	Suggestion
Warning100	For CHPI 10KTL/12KTL: Problem with fan 1 or fan 2.For CHPI 18KTL/20KTL: Problem with fan 1, fan 2, fan 3 or fan 4.	<ol style="list-style-type: none"> 1. Check whether there is anything above fans, clear them; 2. Turn off dc switch, rotate fan blade with screwdriver, then restart inverter. 3. If Warning still exist, Contact Astronergy.
Warning103	Fail to read EEPROM.	Restart the inverter. If the warning still exist, please contact Astronergy customer service to replace the COM board.
Warning 105	Fail to write EEPROM.	Restart the inverter. If the warning still exist, please contact Astronergy customer service to replace the COM board.

10.2.3 Inverter fault

Error code	Meanings	Suggestion
Error: 101	Communication board has not received data from control board for 10 seconds. Electromagnetic Interference cause communication problem.	<ol style="list-style-type: none"> 1. Restart inverter by cutting off DC supply, and Error message will disappear. 2. If the error 101 is often displayed, the environment Electromagnetic Interference is too strong. Contact Astronergy.
Error: 103	data from control board for 10 seconds.	Restart inverter, if problem still exist, Contact Astronergy.
Error: 117	Electromagnetic Interference cause	Restart inverter, if problem still exist, Contact Astronergy.
Error: 119	communication problem.	Restart inverter, if problem still exist, Contact Astronergy.
Error: 121	Control board has not received data from Communication board for 5S.	Restart inverter, if problem still exist, Contact Astronergy.

11. Specifications

Input Data	CHPI 10KTL	CHPI 12KTL	CHPI 18KTL	CHPI 20KTL
Max. DC power	10500W	12500W	18700W	20800W
Max. DC voltage	1000V	1000V	1000V	1000V
Start Voltage	350V	350V	350V	350V
PV voltage range MPPT	180V-1000V	180V-1000V	180V-1000V	180V-1000V
MPP voltage range/ nominal voltage	300V-1000V/ 600V	300V-1000V/ 600V	300V-1000V/ 600V	300V-1000V/ 600V
Full load DC voltage range	400V-800V	400V-800V	400V-800V	400V-800V
Max. input current	15A / 15A	17A / 17A	23A / 23A	26A / 26A
Max. input current per string	20A	20A	20A	20A
Number of independent MPP trackers/strings per MPP tracker	2/2	2/2	2/2	2/3
Output (AC)				
Max. AC apparent power	10kVA	12kVA	18kVA	20kVA
Max. AC output power	10kW	12kW	18kW	20kW
Nominal AC output power	9kW	10.8kW	16.2kW	18kW
Max. output current	16A	19A	28.6A	32A
AC nominal voltage; range	3/N/PE, 230V/400V; 184~275V	3/N/PE, 230V/400V; 184~275V	3/N/PE, 230V/400V; 184~275V	3/N/PE, 230V/400V; 184~275V
AC grid frequency; range	50Hz - 6/+5Hz	50Hz - 6/+5Hz	50Hz - 6/+5Hz	50Hz - 6/+5Hz
Power factor	0.8leading- 0.8lagging	0.8leading- 0.8lagging	0.8leading- 0.8lagging	0.8leading- 0.8lagging
THDI	<3%	<3%	<3%	<3%
AC grid connection type	Three phase	Three phase	Three phase	Three phase
Efficiency				
Max . efficiency	98%	98%	98%	98%
Euro-eta	97.5%	97.5%	97.5%	97.5%
MPPT efficiency	99.5%	99.5%	99.5%	99.5%
Protection devices				
DC reverse polarity protection	yes	yes	yes	yes
DC switch for each MPPT	yes	yes	yes	yes
Output over current protection	yes	yes	yes	yes
Output AC overvoltage Protection - Varistor	yes	yes	yes	yes
Ground fault monitoring	yes	yes	yes	yes
Grid monitoring	yes	yes	yes	yes
Integrated all-pole sensitive leakage current monitoring unit	yes	yes	yes	yes

General Data	CHPI 10KTL	CHPI 12KTL	CHPI 18KTL	CHPI 20KTL
Dimensions (W / H / D) in mm	740/440/235 mm 29.1/17.3/9.3 inch	740/440/235 mm 29.1/17.3/9.3 inch	740/440/235 mm 29.1/17.3/9.3 inch	740/440/235 mm 29.1/17.3/9.3 inch
Weight	41kg/90.4lb	41kg/90.4lb	60kg/132.3lb	60kg/132.3lb
Operating temperature range	-25 °C ... +60 °C / (-13 °F ... +140 °F) / With derating above 45 °C(113 °F)			
Noise emission (typical)	≤ 55 dB(A)	≤ 55 dB(A)	≤ 55 dB(A)	≤ 55 dB(A)
Altitude	2000m(6560ft) without derating			
Self-consumption night	<0.5 W	<0.5 W	<0.5 W	<0.5 W
Topology	Transformerless	Transformerless	Transformerless	Transformerless
Cooling concept	Smart cooling	Smart cooling	Smart cooling	Smart cooling
Environmental Protection Rating	IP 65	IP 65	IP 65	IP 65
Relative humidity	0...95% Non-condensing	0...95% Non-condensing	0...95% Non-condensing	0...95% Non-condensing

Features	CHPI 10KTL	CHPI 12KTL	CHPI 18KTL	CHPI 20KTL
DC connection	H4/MC4(opt)	H4/MC4(opt)	H4/MC4(opt)	H4/MC4(opt)
AC connection	Screw terminal	Screw terminal	Screw terminal	Screw terminal
Display	LCD	LCD	LCD	LCD
Interfaces: RS232/RS485/ Bluetooth/RF/Zigbee/Wifi	yes/yes/opt/opt /opt/opt	yes/yes/opt/opt /opt/opt	yes/yes/opt/opt /opt/opt	yes/yes/opt/opt /opt/opt
Warranty: 5years/10years	yes /opt	yes /opt	yes /opt	yes /opt
Certificates and approvals	VDE-AR-N4105, BDEW, CEI 0-21, RD1669, VDE 0126-1-1, G59, IEC 62109, CE, AS4777, AS/NZS 3100, etc.			

12. Astronergy Factory Warranty

This certificate represents a 5 year warranty for the Astronergy inverter products listed below. Possession of this certificate validates a standard factory warranty of 5 years from the date of purchase.

Warranted products

This warranty is applicable solely to the following products: CHPI 1.5KTL, CHPI 2KTL, CHPI 3KTL, CHPI 4.4KTL, CHPI 5KTL, CHPI 1.5KTL-AS, CHPI 2KTL-AS, CHPI 3KTL-AS, CHPI 5KTL-AS, CHPI 3.6KTL-M2, CHPI 4.2KTL-M2, CHPI 5KTL-M2, CHPI 10KTL, CHPI 12KTL, CHPI 18KTL, CHPI 20KTL

Limited Product Warranty

(Applicable under normal application, installation, use and service conditions) Astronergy warrants the above listed products to be free from defects and/or failure specified for a period not exceeding five (5) years from the date of sale as shown in the Proof of Purchase to the Original purchaser.

The warranties described in these “Limited Warranties ” are exclusive and are expressly in lieu of and exclude all other warranties, whether written, oral, express or implied, including but not limited to, warranties of merchantability and of fitness for a particular purpose, use ,or application, and all other obligations or liabilities on the part of Astronergy , unless such other obligations or liabilities are expressly agreed to it in writing signed and approved by Astronergy , Astronergy shall have no responsibility or liability whatsoever for damage or injury to persons or property, or for other loss or injury resulting from any cause whatsoever arising out of or related to the modules, including, without limitation, any defects in the modules or from use or installation. Under no circumstances shall Astronergy be liable for incidental , consequential or special damages howsoever caused; loss of use, loss of production, loss of revenues are therefore specifically and without limitation excluded to the extent legally permissible, Astronergy ’s aggregate liability, if any, in damages or otherwise, shall not exceed the invoice as paid by the customer.

The “ Limited Product Warranties ” described above shall not apply to, and Astronergy shall have no obligation of any kind whatsoever with respect to, any inverter which has been subjected to:

- Misuse, abuse, neglect or accident;
- Alteration, improper installation or application;
- Unauthorized modification or attempted repairs;
- Insufficient ventilation of the product;
- Transport damage;
- Breaking of the original manufacturers seal;
- Non-observance of Astronergy installation and maintenance instruction;
- Failure to observe the applicable safety regulations
- Power failure surges, lightning, flood, fire, exposure to incorrect use, negligence, accident, force majeure, explosion, terrorist act, vandalism or damage caused by incorrect installation, modification or extreme weather conditions or other circumstances not reasonably attributable to Astronergy.

The warranty shall also cease to apply if the product cannot be correctly identified as the product of Astronergy. Warranty claims will not be honored if the type of serial number on the inverters have been altered, removed or rendered illegible.

Liability

The liability of Astronergy in respect of any defects in its PV inverters shall be limited to compliance with the obligations as stated in these terms and conditions of warranty. Maximum liability shall be limited to the sale price of the product. Astronergy shall accept no liability for loss of profit, resultant of indirect damage, any loss of electrical power and / or compensation of energy suppliers within the express meaning of that term.

The warranty rights as meant herein are not transferable or assignable to any third party excepting the named warranty holder.

13. Warranty Conditions

If a device becomes defective during the agreed Astronergy factory warranty period and provided that it will not be impossible or unreasonable, the device will be, as selected by Astronergy,

1. Shipped to a Astronergy service center for repair, or
2. repaired on-site, or
3. exchanged for a replacement device of equivalent value according to model and age.

The warranty shall not cover transportation costs in connection with the return of defective modules. The cost of the installation or reinstallation of the modules shall also be expressly excluded as are all other related logistical and process costs incurred by all parties in relation to this warranty claim.

14. Contact

If you have technical problems concerning our products, contact your installer or Astronergy. During inquiring, please provide below information:

1. Inverter type
2. Modules information
3. Communication method
4. Serial number of Inverters
5. Error code of Inverters
6. Display of inverters



CORPORATE HEADQUARTERS

Chint Solar (ZheJiang) Co., Ltd.
 1335 Bin'an Road, Binjiang District
 Hangzhou, Zhejiang Province, 310053
 China
 Tel: + 86 571 5603 1888
 Fax: + 86 571 5603 2383

MANUFACTURING PLANTS

Hangzhou, Shanghai & Jiuquan

SUBSIDIARIES

Spain
 Chint Solar Hispania S.L.
 Paseo de Gracia, 78, 2-2A
 08008 Barcelona,
 Spain
 Tel: + 34 9346 73778
 Fax: + 34 9346 73789

Germany
 Astronergy GmbH
 Karlstr. 8
 88212 Ravensburg,
 Germany
 Tel: + 49 (0)751 295096-10
 Fax: + 49 (0)751 295096-39

North America
 Astronergy Solar, Inc.
 Suite 1125, 795 Folsom Street,
 San Francisco, CA 94107
 USA
 Tel: +1 650 392 2777

Japan
 KoyoAstro Co., Ltd.
 1-5-6, Higashi-Nihonbashi, Chuo-ku,
 Tokyo 103-0004,
 Japan
 Tel: + 03 5820 2141
 Fax: + 03 5820 2142

Korea
 Astronergy Solar Korea
 5t h FL. Cowell Bldg, 66-1,
 Banpo-Dong, Seocho-Gu,
 Korea
 Tel: + 82 (0)2 2226 3911
 Fax: + 82 (0)2 2226 3910

Thailand
 Astronergy Solar Korea (Thailand) Co., Ltd.
 184/88 Forum Tower 18FL
 Ratchadapisek Rd., Huay-Kwang,
 Bangkok 10320
 Thailand
 Tel: + 662 645 4155
 Fax: + 662 245 3185